

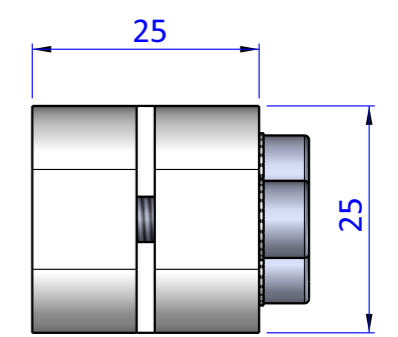

THE PROPERTY OF THE DRAWING IS ESTABLISHED BY LAW. IT IS FORBIDDEN TO PRODUCE OR SHOW IT TO THIRD PART. WITHOUT A WRITTEN AGREEMENT.

Item	Name	Q.ty
1	GVR.20.1.50	1
2	GVR.20.2	1
3	GVR.20.3	1
4	R.5.SCH	3
5	V.TCE5x25	3

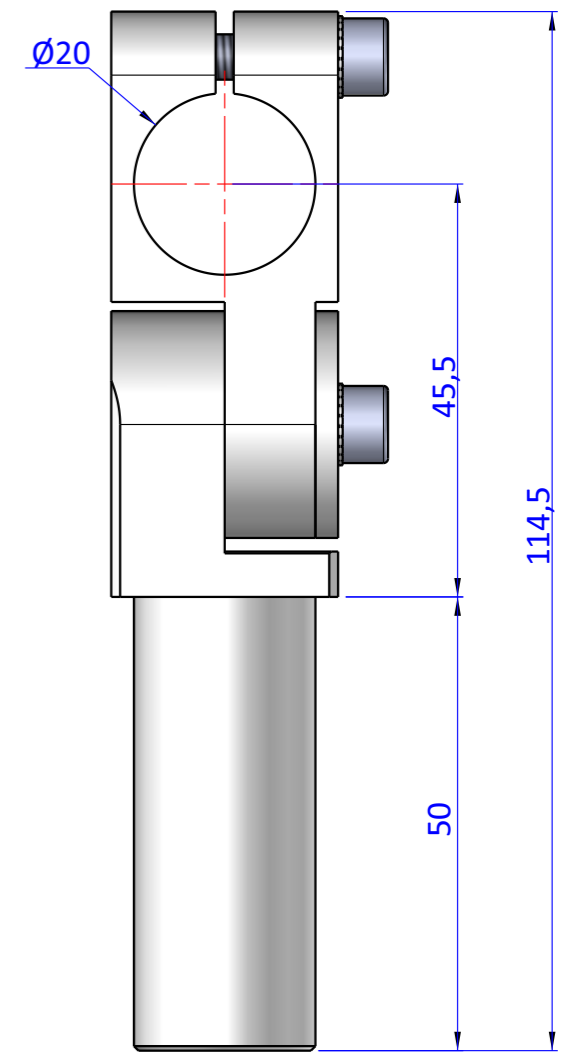
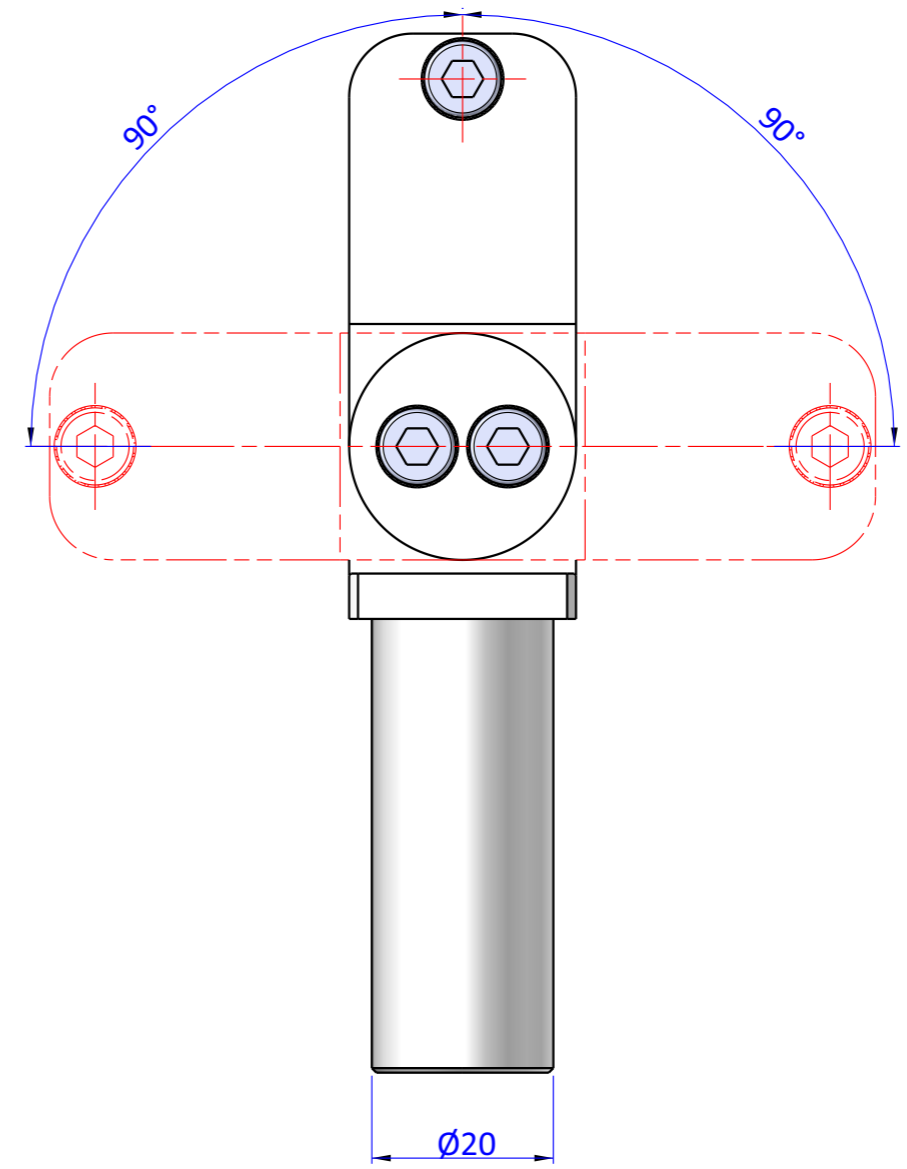
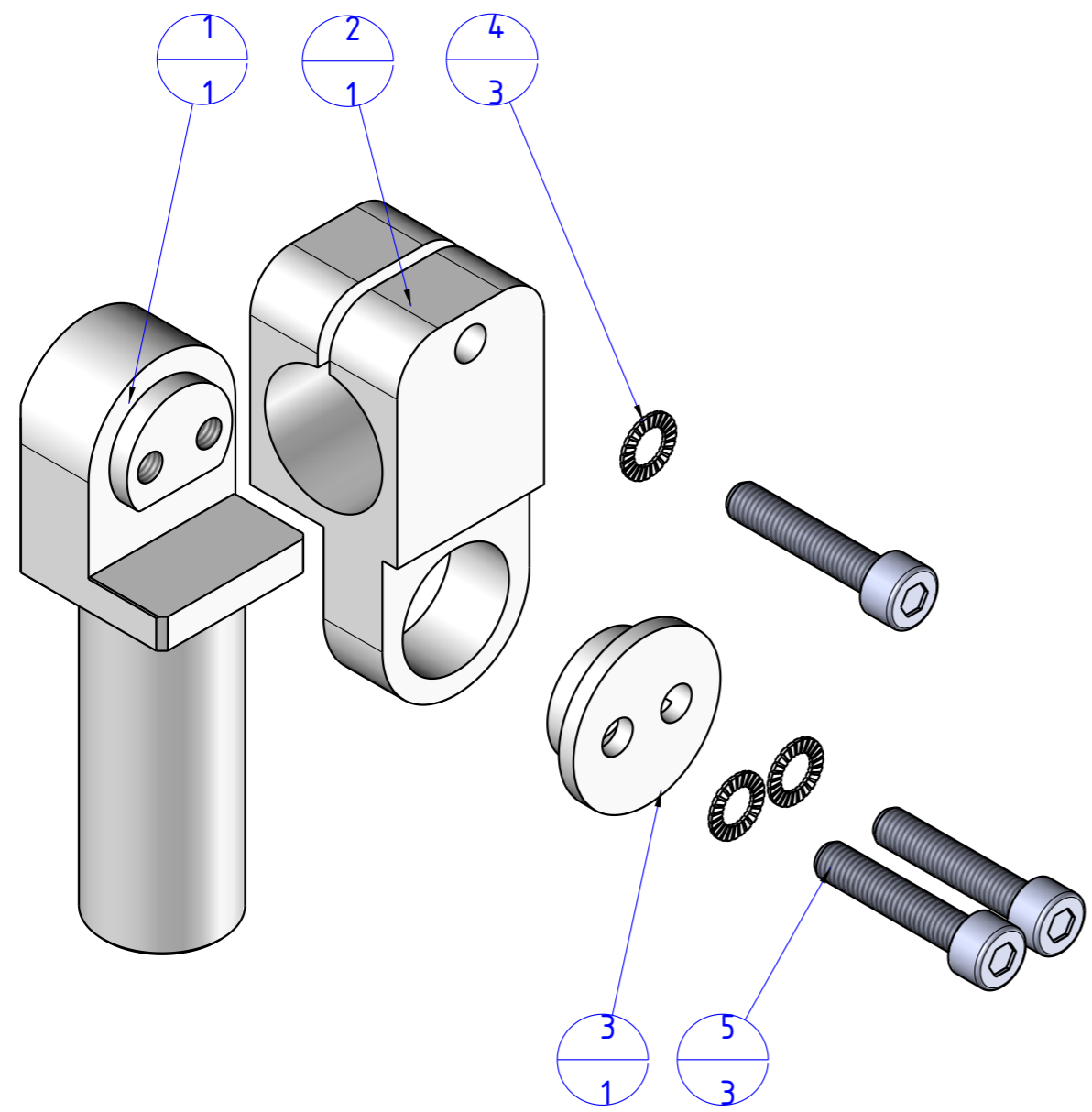

Format A3
UNI 936-76

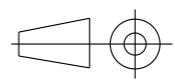
 FPS FPSERVICES AUTOMATION			DESIGNED FROM FPS Automation	REVIEW A
GENERAL TOLERANCE UNI - ISO 2768 CLASSE f	DESCRIPTION CA.GVR.2020.50	DATE 18/09/2020	WEIGHT 0,121kg	CODE CA.GVR.2020.50